

Oster^{®/MD}

VERSA[™] PERFORMANCE BLENDER

The Power to
Blend Everything

MÉLANGEUR PERFORMANCE VERSA^{MC}

La puissance pour
tout mélanger



User Manual / Manuel d'utilisation

Visit us at www.oster.ca

P.N. 173011

IMPORTANT SAFEGUARDS

When using your blender, you should always follow basic safety precautions, including the following:

- Read all instructions before use.
- To protect against electrical hazards, do not immerse the cord, plug or motor base in water or other liquids.
- Always use the product on a clean, flat, hard, dry surface. There should be no material such as a tablecloth or plastic between the unit and surface.
- Flashing control button LED light indicates ready to operate. Avoid any contact with blades or moveable parts.
- Keep hands and utensils out of jar while blending to reduce the risk of:
 - Severe personal injury.
 - Damage to the blender.
- If scraping is necessary, turn the power OFF, unplug from the electrical outlet, and use a rubber spatula only.
- Do not use the appliance:
 - With a damaged cord or plug.
 - After the unit fails to work correctly.
 - After you drop or damage the product in any way.

Return the product to your nearest Authorized Oster™ Appliance Service Center for a safety check, adjustment or repair. Call our toll-free, automated phone line to find the Service Center nearest to you.

- The 6 Point Star Blade is sharp. Handle it carefully. To reduce the risk of injury, never place the blade assembly on the base without a jar properly attached.
- Always put the lid on the jar before operating the blender.
- Do not use outdoors.
- Do not allow the cord to touch hot surfaces or hang over the edge of a table or counter.
- Turn all controls to OFF and unplug the blender when it is not in use, before taking off or putting on parts, and before cleaning.
- Never leave the appliance unattended while it is running.
- You risk personal injury, fire or electric shock if you use attachments, jars or parts other than those recommended by the Oster® brand.
- Supervise children closely when they use or are nearby appliances.
- The use of attachments, including canning or ordinary jar and processing assembly parts, is not recommended by Jarden Consumer Solutions and may cause risk or injury to persons.
- The container should not be more than 2/3 full when the tamper is left in while blending. Do not exceed 20 seconds of continuous blending with the tamper in place.
- When making nut butters or oil based foods, do not process for more than one minute after the mixture starts circulating. Over-processing can cause dangerous overheating.
- When processing hot liquids: the 2-part lid must be securely locked in place. This allows steam to escape naturally, and will prevent the lid from coming off when the machine is turned on. Always start hot liquids on “Low”, then increase to the desired speed in the recipe. Never start on “High” with hot liquids. Use caution with hot liquids.
- Never put non-food items into the pitcher to blend.

SAVE THESE INSTRUCTIONS

This product is for household use only.

- The maximum rating marked on the product is based on the attachment that draws the greatest load. Other attachments may draw less power.

Power Cord Instructions:

Please follow the instructions below to ensure the safe use of the power cord.

- The Oster® Versa™ Performance Blender comes equipped with a three-prong (grounding) plug. If you do not have a three-prong outlet, you can use with an adapter to be able to use with a standard two-prong outlet. Do not cut or remove the third prong from the plug on the power cord.
- Try to position the blender near the power source to reduce the hazards associated with power cords (such as becoming entangled or tripping over a long power cord).
- Do not pull, twist or otherwise abuse the power cord.
- Do not wrap the power cord around the main body of the blender during or after use.
- Do not use an extension cord with this product.



This symbol has been placed in specific areas of the User Guide portion of this book. Its purpose is to help you easily identify instructions that require your special attention.

3-PRONG GROUNDED PLUG

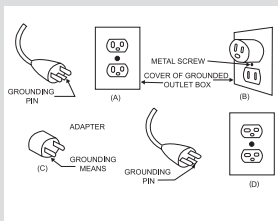

This appliance must be grounded while in use to protect the operator from electric shock. This product is for use on 120 volts. The cord has a plug (A) as shown. An adapter (C) (not included) is available for connecting three-blade grounding-type plugs to two-slot receptacles (B). The green grounding lug extending from the adapter must be connected to a permanent ground such as a properly grounded outlet box. The adapter should not be used if a three-slot grounded receptacle is available.

DO NOT ATTEMPT TO MODIFY THIS PLUG OR DEFEAT THIS SAFETY FEATURE IN ANY WAY.

Table of Contents

English

Important Safeguards	2
Power Cord Instructions	3
Features and Assembly	5
Using the Product Control Panel	6
Using your Product	7
Blending Tips	8
Caring for Your Product	9
Cleaning	9
Storing	9
7 Year Limited Warranty	10
How to Obtain Warranty Service	10

Français

Précautions de sécurité importantes	11
Instructions concernant le cordon électrique.....	12
Caractéristiques et montage	13
Utilisation du tableau de commande de votre appareil	14
Utilisation de votre appareil	15
Conseils de mélange.....	16
Entretien de votre appareil	17
Nettoyage.....	17
Rangement	17
Garantie limitée de 7 ans.....	18
Comment bénéficier de la garantie.....	18

Welcome

Congratulations on the purchase of your Oster® Versa™ Performance Blender. If you have any comments, questions or inquiries about this revolutionary product, please call 1-800-667-8623.

Learning About Your Product Features and Assembly

1. **Filler Cap** – 2 oz / 60 ml filler cap doubles as a measuring cup. Align notch with the hole to insert in lid; turn clockwise to secure in place. Remove from lid to add ingredients while blending.

2. **Lid (Flap goes on opposite side of pour spout)** – Seals the jar.

3. **Jar & Blade Assembly** – BPA-free plastic jar with permanently attached blade assembly.

4. **Jar Sensor** - Unit will not operate unless the jar is fully seated on base and the jar sensor is engaged.

5. **Control Panel** – Includes speed dial, 3 programmed settings and pulse.

6. **Power Cord** – 3-prong power cord.

7. **Fuse** – Incorporated to protect the motor from overheating. If the motor shuts off while in use: Turn control knob to “Off” and unplug from the wall. Remove jar from base and free blade of any obstructions. Wait 30-45 minutes for the unit to cool. Press external resettable fuse button on the bottom of the base.

8. **Cord Storage** – Space on the bottom of the base to store the cord while not in use.

9. **Tamper** – After blending has started, remove the filler cap and place the tamper through the opening in the lid to assist with pushing the food down to the blade.
Note – the tamper is not long enough to reach the blade.

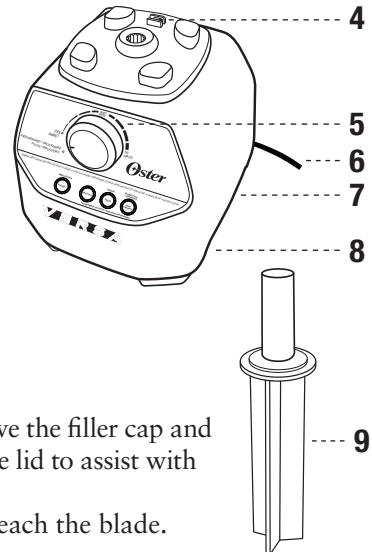
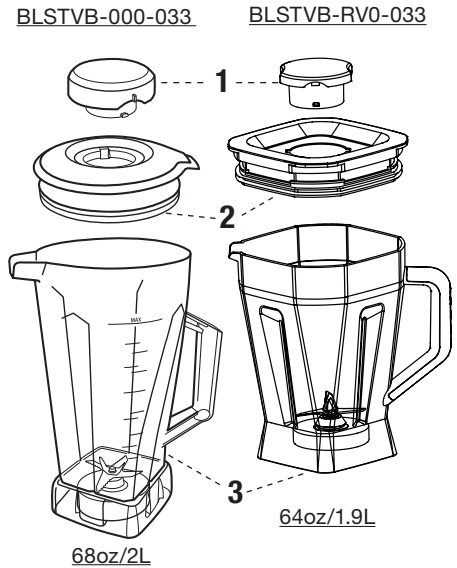

Before you use the product for the first time, separate the Tamper, Lid, Filler Cap, and Jar. Wash in warm, soapy water. Rinse and dry well.

Using Your Product Control Panel

A. Speed Dial – Turn dial clockwise to choose from manual speed settings from “Low” to “High”. Once you select a speed, the blender will run until you turn it back to “Off.”

B. Programmed Settings – In order to activate the programmed buttons, first turn the speed dial counter-clockwise to the Programmed/Pulse Setting. Then select the programmed button you would like to use. They have been developed for optimal use when blending those types of foods.

Soup: 20 second ramp up to “Medium”, 5 minutes on “High”.

Dips/Spreads: 2 (10-second) pulses at “Medium-low”, 30 seconds on “High”.

Smoothie: 10 seconds to ramp up to “Medium”, 20 seconds on “High”.

NOTES:

1. If you would like to stop the blender in the middle of a programmed cycle, simply press any button.
2. For some blending tasks, it may be necessary to supplement the programmed setting with additional blending time.

C. Pulse – Turn the speed dial counter-clockwise to the Programmed/Pulse Setting. Then press the “Pulse” button for the desired time.

D. LED Lights – The lights around the selected programmed buttons will pulse when the unit is operating in that mode.

E. Flashing Light – When speed dial is turned to the Programmed/Pulse setting, the Pulse button light will flash red to indicate the unit is ready to operate. Warning: Flashing light indicates ready to operate. Do not touch the blade.

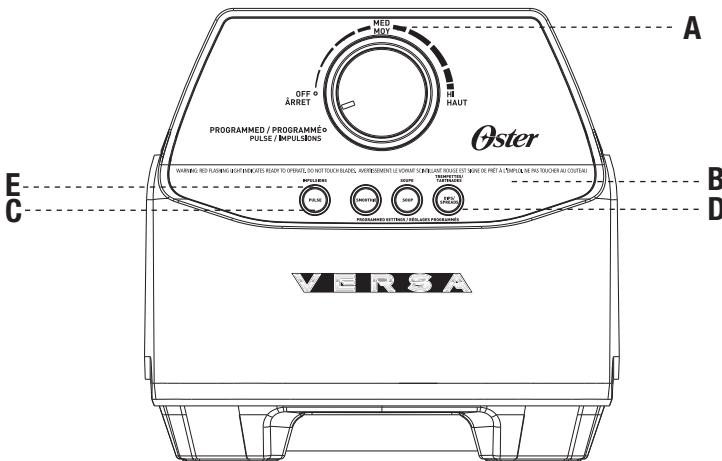

Using your Product

Tamper – The tamper allows you to accelerate the process of very thick and/or frozen mixtures that cannot be processed in a regular blender. If food is not circulating the machine may be overloaded or may have a trapped air bubble. Using the tamper helps to maintain circulation by preventing air pockets from forming. While the machine is running, remove the filler cap, and through the hole in the lid insert the tamper and use it to press ingredients onto the blades as you make frozen ice creams, nut butters, etc.

The container should not be more than 2/3 full when the tamper is used during blending.

Do not use tamper for more than 30 consecutive seconds (to avoid stressing the motor).

You may need to move the tamper not only up and down, but also side to side.

Jar Sensor – The unit is supplied with a jar sensor on the base. This will prevent the motor or the control panel from starting if the blender jar is not properly placed on the base.

If the jar is removed from the base during operation the unit will stop. To restart the blender, turn the speed dial to “Off”, place the jar on the blender base and select the preferred speed to begin again.

NOTE: The motor will not restart unless the unit is turned OFF first.

Blending Tips

- Do not operate for more than 10 minutes at a time.
- Jar should be at least 25% full at all times for optimal performance.
- Filler cap should always be assembled to the lid and locked when blending hot liquids.
- Use High speeds as much as possible for whole fruit/vegetable juices, soups, shakes, frozen mixtures, making purées and nut butters. Processing times will generally be less than one minute (most take less than 30 seconds). High speed provides the best quality of refinement, breaking down ice, frozen fruit, whole fruits or vegetables to a smooth lump-free consistency.
- Never blend without the lid firmly in place on the jar.
- If on High speed the food is not circulating, try using the tamper. If this is also not working, try using a slower speed. Once the food begins to circulate again, you can switch back to a High speed.
- A Quick Response code is located on the back of the base of the unit. Using the Microsoft® Tag application on your smart phone, scan that tag to be directed to the product page to find pertinent product information such as instruction manuals, replacement parts, customer service, recipes, etc.
- Due to the power of the machine, it is normal for it to be fairly loud during operation. Through the blending cycle, the noises may change, but there is no need to be concerned.

Ice Crushing: For optimal ice crushing, fill the jar with preferred amount of ice. Then fill with water just above where the ice stops. Use the speed dial to blend on High for a few seconds. Then drain out the excess water and you are left with a jar filled with great consistent ice!

Troubleshooting:

1. If the blender does not turn on:

1. Turn control knob to “OFF” position and unplug from electrical outlet.
2. Make sure the blade is free of any obstruction.
3. Plug the unit back in.
4. Make sure jar is securely placed on the blender base.
5. Restart unit by turning control knob to desired setting.

2. If the blender stops during operation:

1. Fuse/Overload Protection activated
 1. The motor is designed to protect itself from overheating; when necessary, the motor will turn itself off.
2. Reset the motor by:
 1. Turn control knob to “OFF” and unplug from electrical outlet.

2. Remove the jar from the base and free the blade of any obstructions.
 3. Wait 30-45 minutes for the unit to cool.
 4. Press the resettable fuse button located on the bottom of the base.
2. Jar Sensor on base released
1. To restart the unit, turn control knob to “OFF“ position.
 2. Make sure the jar is securely placed on the blender base.
 3. Restart the blender by turning the control knob to the desired setting.

If the warning light flashes and the motor will not run with the jar in place, the unit has not cooled sufficiently. Turn the control knob to “Off” and wait another 10-20 minutes before trying again.

Caring for Your Product

Cleaning

Base: First turn the control to “Off” and unplug the power cord. Then wash outside surface with a damp soft cloth or sponge using mild soap and warm water. Never immerse the motor base in water or other liquid.

Jar: Fill the container half full with warm water and add 2 drops of liquid soap. Close the jar with the lid and filler cap. Turn Speed Dial to a “Low” speed and then increase to “High”. Run for 30-60 seconds. Turn the machine OFF, rinse the jar out with running water then dry.

Lid & Filler cap: Separate the 2 pieces and wash in warm soapy water. Rinse clean under running water, then dry.

NOTE - Do not put lid, filler cap or jar in the dishwasher.

Storing

After cleaning, store with lid not closed completely to allow air to circulate and prevent container odors.



WARNING: Never put the jar or any other parts in a microwave. Never store foods or drinks in the jar.

7 Year Limited Warranty

Sunbeam Products, Inc. doing business as Jarden Consumer Solutions or if in Canada, Sunbeam Corporation (Canada) Limited doing business as Jarden Consumer Solutions (collectively “JCS”) warrants that for a period of seven years from the date of purchase, this product will be free from defects in material and workmanship. JCS, at its option, will repair or replace this product or any component of the product found to be defective during the warranty period. Replacement will be made with a new or remanufactured product or component. If the product is no longer available, replacement may be made with a similar product of equal or greater value. This is your exclusive warranty. Do NOT attempt to repair or adjust any electrical or mechanical functions on this product. Doing so will void this warranty.

This warranty is valid for the original retail purchaser from the date of initial retail purchase and is not transferable. Keep the original sales receipt. Proof of purchase is required to obtain warranty performance. JCS dealers, service centers, or retail stores selling JCS products do not have the right to alter, modify or any way change the terms and conditions of this warranty.

This warranty does not cover normal wear of parts or damage resulting from any of the following: negligent use or misuse of the product, use on improper voltage or current, use contrary to the operating instructions, disassembly, repair or alteration by anyone other than JCS or an authorized JCS service center. Further, the warranty does not cover: Acts of God, such as fire, flood, hurricanes and tornadoes.

What are the limits on JCS's Liability?

JCS shall not be liable for any incidental or consequential damages caused by the breach of any express, implied or statutory warranty or condition.

Except to the extent prohibited by applicable law, any implied warranty or condition of merchantability or fitness for a particular purpose is limited in duration to the duration of the above warranty. JCS disclaims all other warranties, conditions or representations, express, implied, statutory or otherwise. JCS shall not be liable for any damages of any kind resulting from the purchase, use or misuse of, or inability to use the product including incidental, special, consequential or similar damages or loss of profits, or for any breach of contract, fundamental or otherwise, or for any claim brought against purchaser by any other party. Some provinces, states or jurisdictions do not allow the exclusion or limitation of incidental or consequential damages or limitations on how long an implied warranty lasts, so the above limitations or exclusion may not apply to you.

This warranty gives you specific legal rights, and you may also have other rights that vary from province to province, state to state or jurisdiction to jurisdiction.

How to Obtain Warranty Service

In the U.S.A.

If you have any question regarding this warranty or would like to obtain warranty service, please call 1-800-334-0759 and a convenient service center address will be provided to you.

In Canada

If you have any question regarding this warranty or would like to obtain warranty service, please call 1 800-667-8623 and a convenient service center address will be provided to you. In the U.S.A., this warranty is offered by Sunbeam Products, Inc. doing business as Jarden Consumer Solutions located in Boca Raton, Florida 33431. In Canada, this warranty is offered by Sunbeam Corporation (Canada) Limited doing business as Jarden Consumer Solutions, located at 20 B Hereford Street, Brampton, Ontario L6Y 0M1. If you have any other problem or claim in connection with this product, please write our Consumer Service Department.

***PLEASE DO NOT RETURN THIS PRODUCT TO ANY OF THESE ADDRESSES
OR TO THE PLACE OF PURCHASE.***



For product questions contact:
Sunbeam Consumer Service
USA : 1.800.334.0759
Canada : 1.800.667.8623
www.oster.ca

© 2013 Sunbeam Products, Inc. doing business as Jarden Consumer Solutions.
All rights reserved. In Canada, imported and distributed by Sunbeam Corporation (Canada)
Limited doing business as Jarden Consumer Solutions, 20 B Hereford Street, Brampton,
Ontario L6Y 0M1.

Pour les questions de produit:
Service aux consommateurs Sunbeam
États-Unis : 1.800.334.0759
Canada : 1.800.667.8623
www.oster.ca

© 2013 Sunbeam Products, Inc. faisant affaires sous le nom de Jarden Consumer Solutions.
Au Canada, importé et distribué par Sunbeam Corporation (Canada)
Limited faisant affaire sous le nom de Jarden Consumer Solutions,
20 B Hereford Street, Brampton (Ontario) L6Y 0M1.